

チェーンソーミル (KM0403WS) 部品表

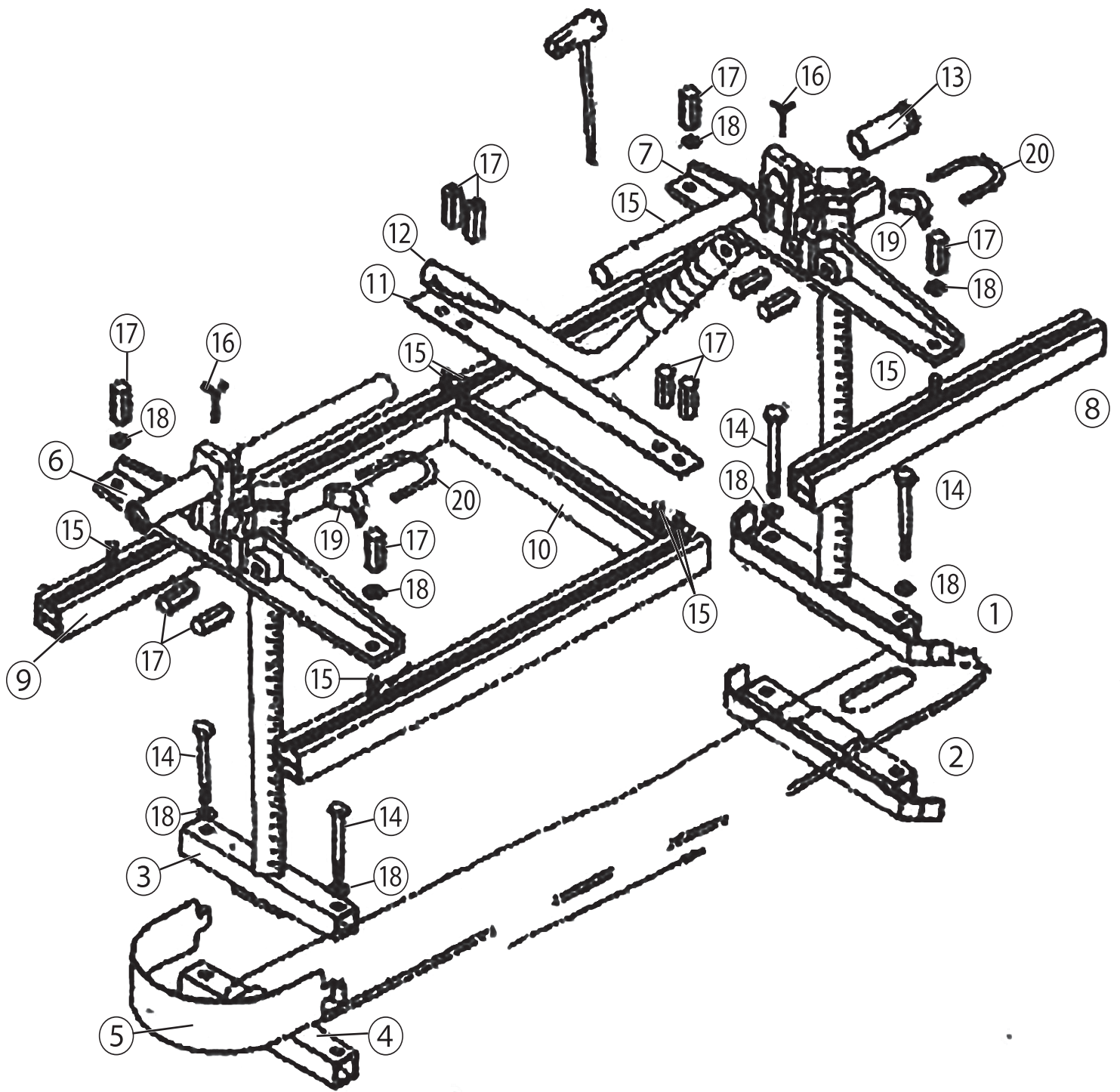

NO	P/N	数量	品名	NO	P/N	数量	品名
1.	791	1	ADJ.POST/THRUST EMD	11.	784	1	TIE BAR
2.	790	1	CLMP BRKT./THRUST END	12.	596	1	HANDLE & GRIP
3.	792	1	ADJ.POST/NOSEEND	13.	793	1	HANDLE
4.	788	1	CLMP BRKT./NOSE END	14.	779	4	HEX BOLT 5/16-18X3-1/2
5.	795	1	NOSE GUARD	15.	805	8	CRG BOLT 5/16-18X3/4
6.	782	1	END BRACKET	16.	809	2	PAN HD.SCREW
7.	782	1	END BRACKET	17.	702	12	COUPLING NUT 5/16-16
8.	781	1	THICKNESS RAIL	18.	871	8	FLAT WASHER.5/16
9.	781	1	THICKNESS RAIL	19.	804	2	POST CLAMP
10.	799	1	ON-OFF GUIDE BAR	20.	1794	2	U-CLAMP.5/16-18

1

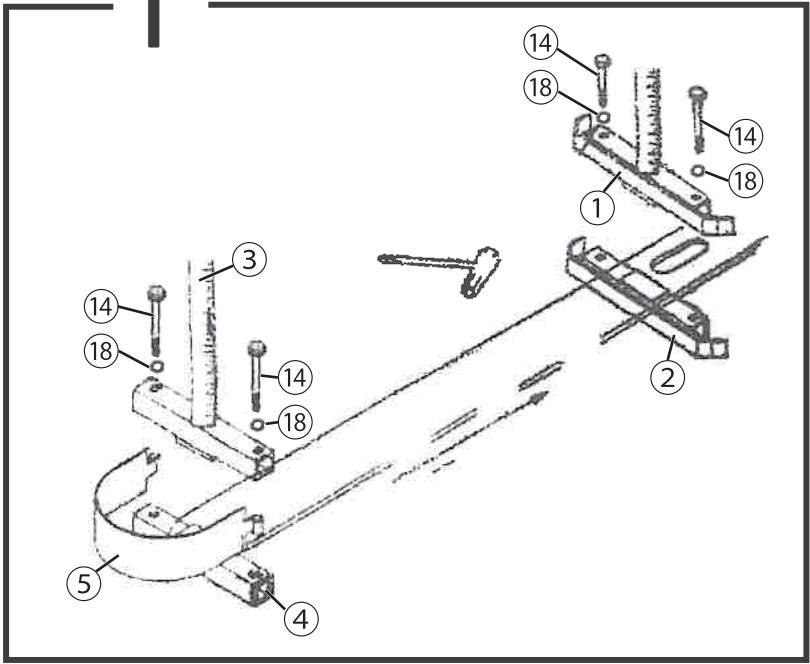

3

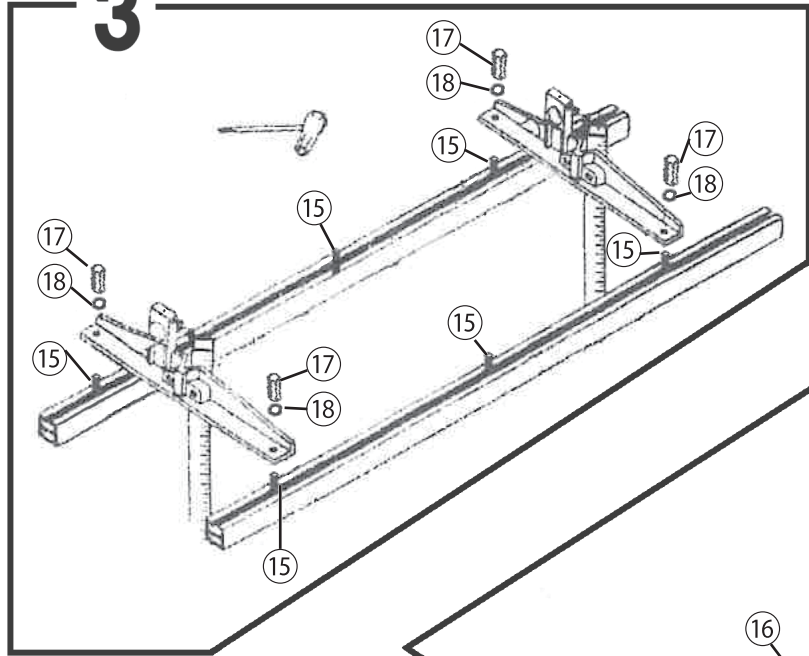

5

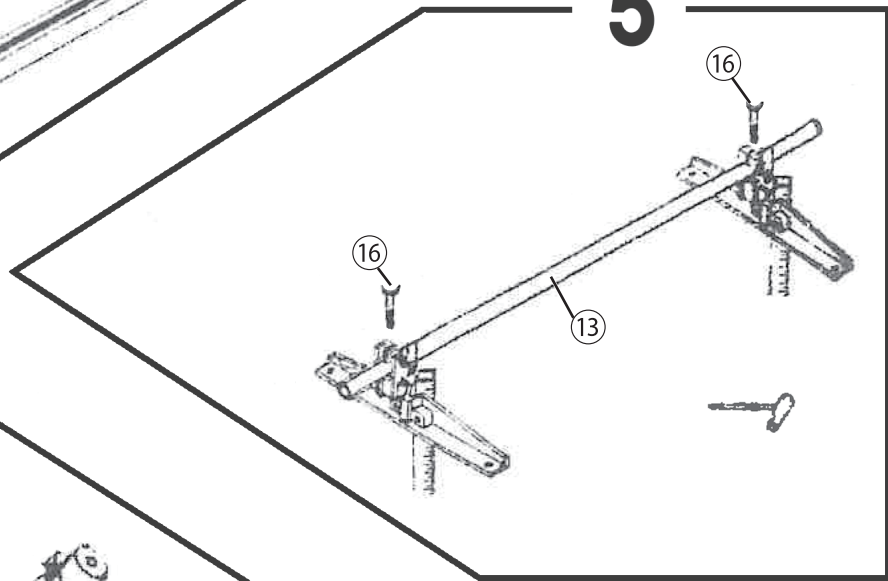

2

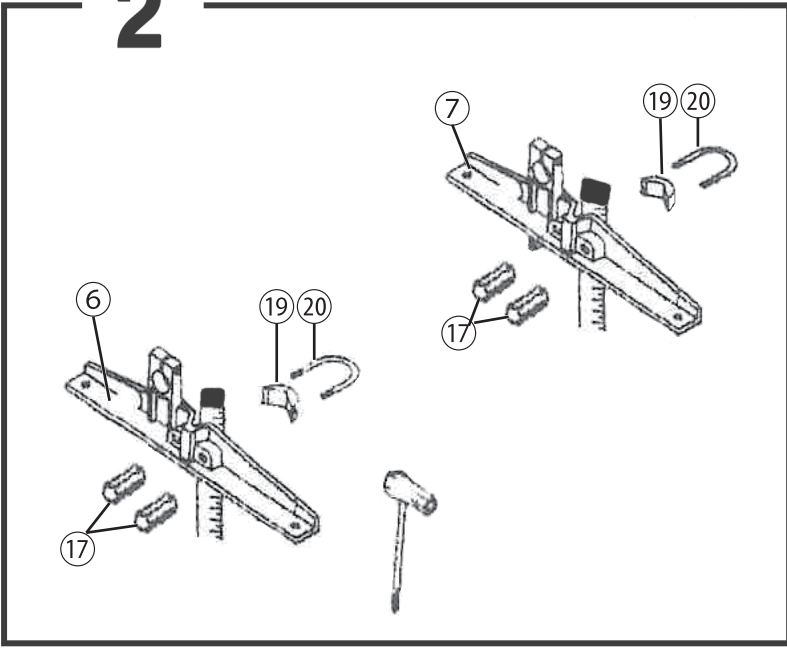

4

